



JOHN DEERE

PowerTech™ 4045H Diesel Engine Specifications

PERFORMANCE DATA

Rated Power

Intermittent	173 hp (129 kW) @ 2400 rpm
Continuous	156 hp (116 kW) @ 2400 rpm

Peak Torque

Intermittent	476 lb-ft (645 N.m) @ 1400 rpm
--------------	--------------------------------

Fuel Economy

BSFC	0.355 lb/hp-hr (216 g/kWh) @ 2400 rpm
------	---------------------------------------

RATED BHP is the power rating for variable speed and load applications where full power is required intermittently.
 CONTINUOUS BHP is the power rating for applications operating under a constant load and speed for long periods of time.
 POWER OUTPUT is within + or - 5% at standard SAE J 1995 and ISO 3046.
 TIER 2 EMISSION CERTIFICATIONS: CARB, EPA, and EU.

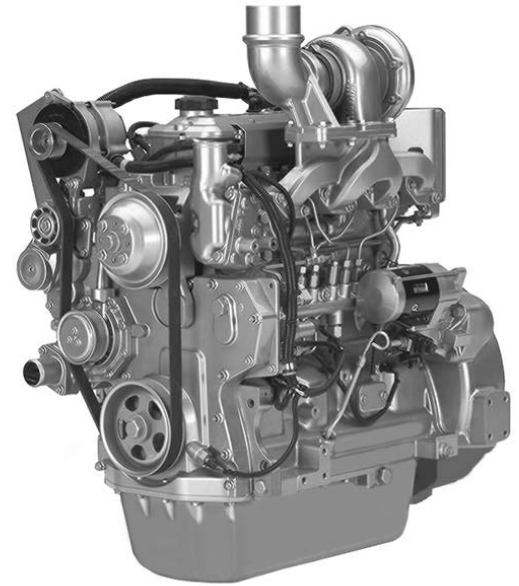

PERFORMANCE CURVE

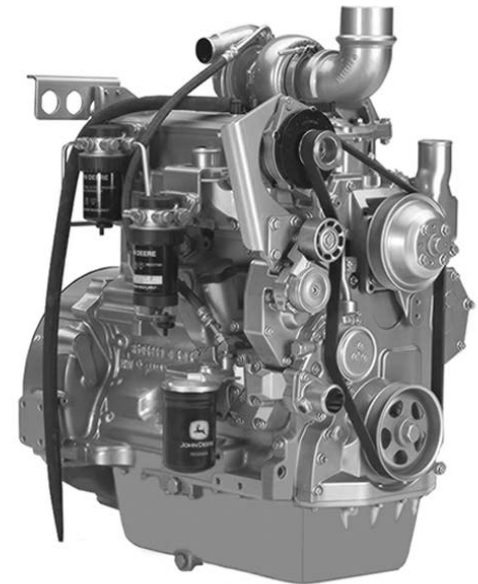
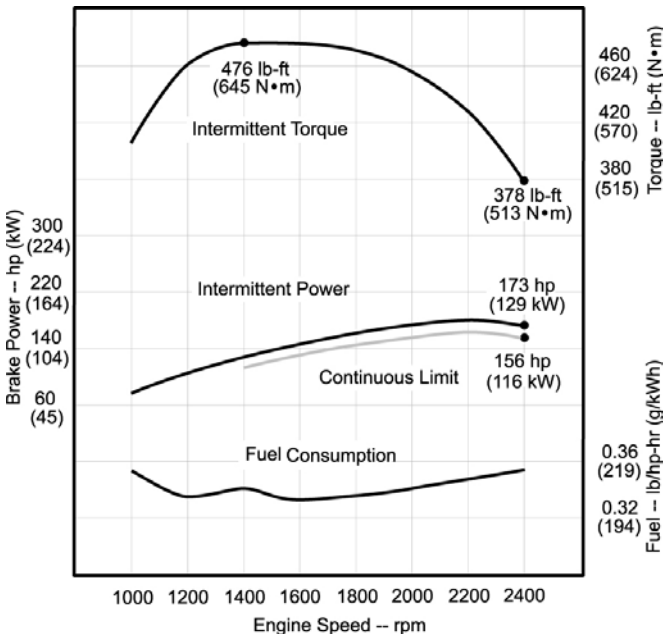

Photographs may show non-standard equipment



PowerTech™
4045H Diesel Engine
Specifications

GENERAL DATA

Model	4045HF475	Aspiration	Air-to-Air
Number of Cylinders	4	Length - in. (mm)	33.9 (860)
Displacement - L (cu.in)	4.5 (276)	Width - in. (mm)	24.1 (612)
Bore and Stroke - in. (mm)	4.19 x 5.00 (106 x 127)	Height - in. (mm)	39.1 (994)
Compression Ratio	17.0:1	Weight - lb. (kg)	993 (451)
Engine Type	In-line, 4-Cycle		

DIMENSIONS

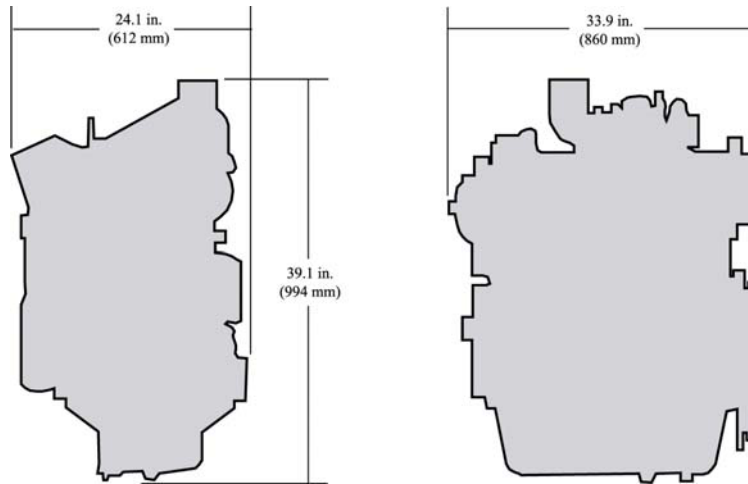

FEATURES AND BENEFITS

High Power Density

- High power density allows an OEM to use engines of a smaller displacement, reducing installed cost

Glow Plugs

- Glow plugs and pilot injection provide superior cold weather starting

Common Block

- The 4-valve engines share a common block with 2-valve engines for application ease

4-Valve Cylinder Head

- New cylinder head with 4-valve design provides increased air flow for superior performance

Centered, Vertical Injectors

- Engines burn cleaner, resulting in lower emission and improved fuel economy with the aid of vertical injectors

High-Pressure Common Rail Fuel System

- With the HPCR, the fuel pump sends constant pressure into a common rail, supplying each injector with constant pressurized fuel that is available when the electronic injector opens
- New injectors are vertical and centered over the pistons, which allows for improved burning of fuel

Exhaust Port Liners

- Exhaust port liners result in best-in-class heat rejection

500-Hour Oil Change

- Customers save significant costs on oil, filters and labor with a 500-hour oil change interval

Specifications and design subject to change without notice



John Deere Power Systems
3801 W. Ridgeway Ave.
PO Box 5100
Waterloo, IA 50704-5100
Phone (800) 533-6446
Fax (319) 292-5075

John Deere Power Systems
Usine de Saran
La Foulonnerie - B.P. 11013
45401 Fleury-les-Aubrais Cedex-France
Phone (33) 2 38 82 61 19
Fax (33) 2 38 82 60 00