

BELL POWER SYSTEMS BILL OF MATERIALS	
A	XXXXXXXXXX
B	XXXXXXXXXXXX
C	XXXXXXXXXXXX
D	XXXXXXXXXXXX
E	XXXXXXXXXXXX
F	XXXXXXXXXXXX
G	XXXXXXXXXXXX
H	XXXXXXXXXXXX

CONTROLLED COPY
RETURN TO ENGINEERING UPON COMPLETION

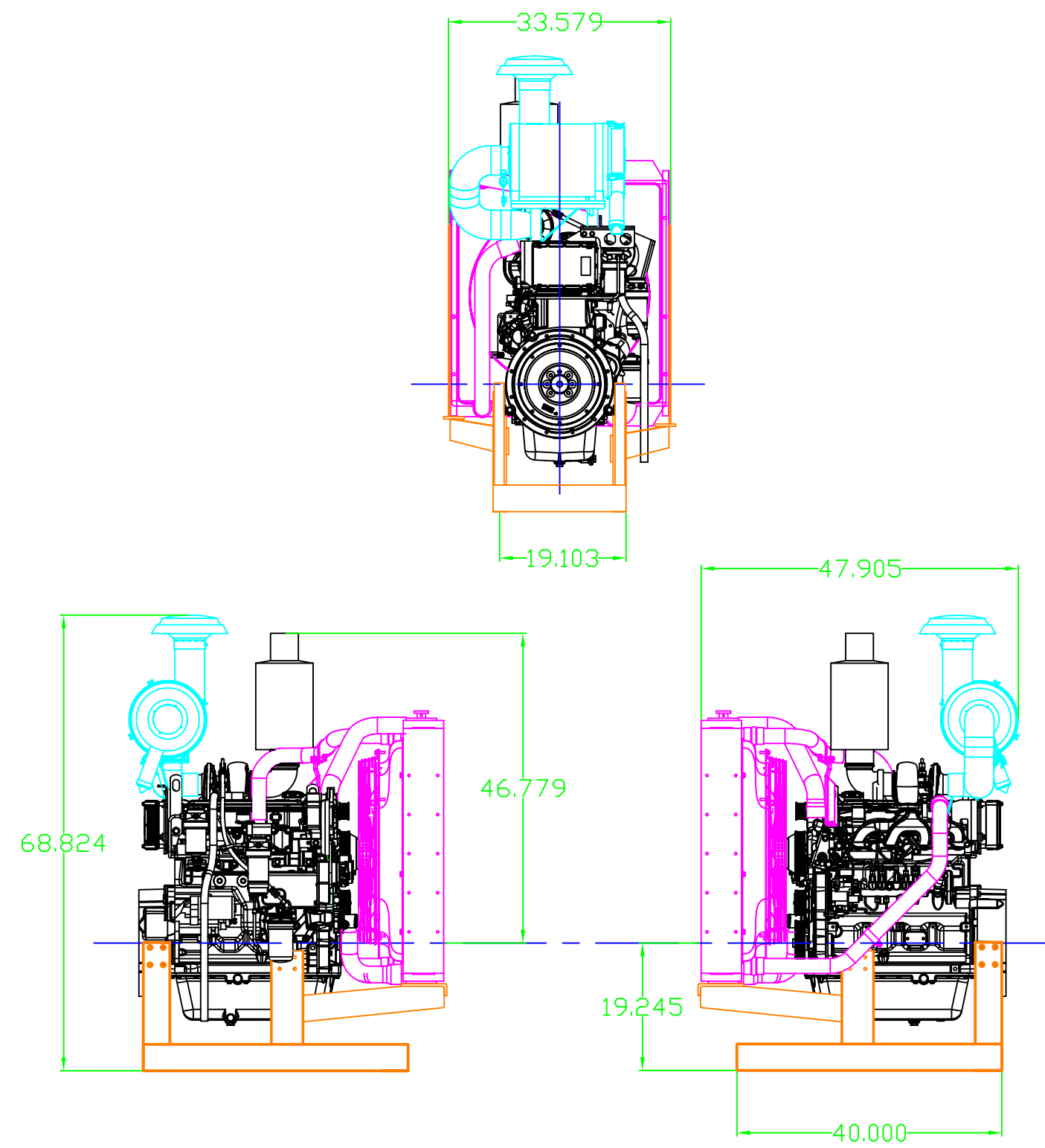

4045HF475
REVISED: 9-27-05
D.R.

<small>PROPRIETARY DOCUMENT THIS DRAWING MAY NOT BE REPRODUCED OR USED FOR THE PURPOSE OF MANUFACTURING.</small>		BELL WORK ORDER NO.: XXX	
<small>ALL INFORMATION PROVIDED IS THE EXCLUSIVE PROPERTY OF:</small>		Bell DEERE POWER SYSTEMS, INC. POWER <small>ESSEX, CONNECTICUT</small>	
<small>SIZE</small>	<small>FSCM NO.</small>	<small>DWG NO.</small>	<small>REV</small> B
<small>SCALE</small>		<small>ENGINEER: RJB</small>	<small>DATE: 09-27-05</small>

USER FNAME

REVDATE

USER MAXX